

ITEM

1829PR26B0

PROLUNGA FLANGIA 1"X26X245

Product Type

Traps and basket wastes for kitchen sinks

Kitchen sink traps accessories



Logistic Info

Pcs per Carton:

Qty per Pallet: 5

Unit weight: 0,03200

Flow rate Lt/m.:

ORIGINE: MADE IN ITALY

Cod.EAN13: 8030575003023

Tarif Code :39229000

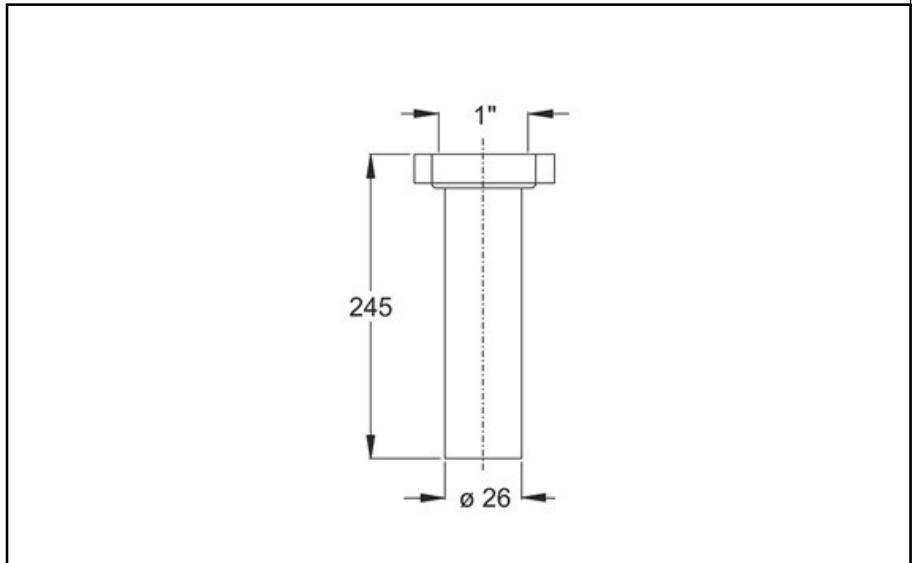

Tecnichal Details

Model: EXTENSION PIPES

Product: Flanged extension

Spec 1: Plastic nut, flat washer

Spec 2: 1" - ø 26 x 245 mm

Material 1: PP

Material 2:

Color 1: WHITE

Color 2:

Approvals